

## Dati tecnici

### MIKRON XSM 400, XSM 400U

		MIKRON XSM 400	MIKRON XSM 400U
<b>Corse</b>			
Longitudinale, asse, X	mm	400	400
Trasversale, asse, Y	mm	450	240
Verticale, asse, Z	mm	350	350
Asse basculante, B	°	-	+110/-110
Asse rotante, C	°	-	n x 360
<b>Mandrino di lavoro (40% ED, S6)</b>			
30'000 min <sup>-1</sup> , HSK-E40	kW / Nm	12 / 8.8	12 / 8.8
42'000 min <sup>-1</sup> , HSK-E40	kW / Nm	13 / 4.2	13 / 4.2
54'000 min <sup>-1</sup> , HSK-E32	kW / Nm	8.5 / 3.5	8.5 / 3.5
<b>Velocità</b>			
Lavoro/Rapido (X, Y, Z)	m/min	20 / 100	20 / 100
Rapido (B)	min <sup>-1</sup>	-	165
Rapido (C)	min <sup>-1</sup>	-	250
<b>Tavola</b>			
Superficie	mm	320 x 320	Ø156 (110x110)
Standard	System 3R/Erowa	Dynafix/GPS240/UPC	Macro/Macro Magnum/ ITS148
Carico massimo	kg	200	25
<b>Cambio utensili</b>			
Magazzino utensili HSK-E32	Posti	20 / 40	20 / 40
Magazzino utensili HSK-E40	Posti	18 / 36 / 68	18 / 36 / 68
Max. lunghezza utensili	mm	200 (Anello interno: 125)	155 (Anello interno: 100)
Max. diametro utensili	mm	65 (Anello interno: 30)	65 (Anello interno: 30)
Max. peso utensili	kg	2	2
<b>Cambio pallet</b>			
Magazzino pallet	Posti	7 / 10 (GPS)	18 / 20 (ITS) / 48 (Macro)
Carico massimo	kg	80	80
<b>Controllo numerico</b>			
	Typ	Heidenhain iTNC 530 2P	Heidenhain iTNC 530 2P
<b>Peso della macchina</b>			
Macchina	kg	6'500	6'700
Cambio pallet	kg	1'000	1'000
smart machine	www.gfac.com		

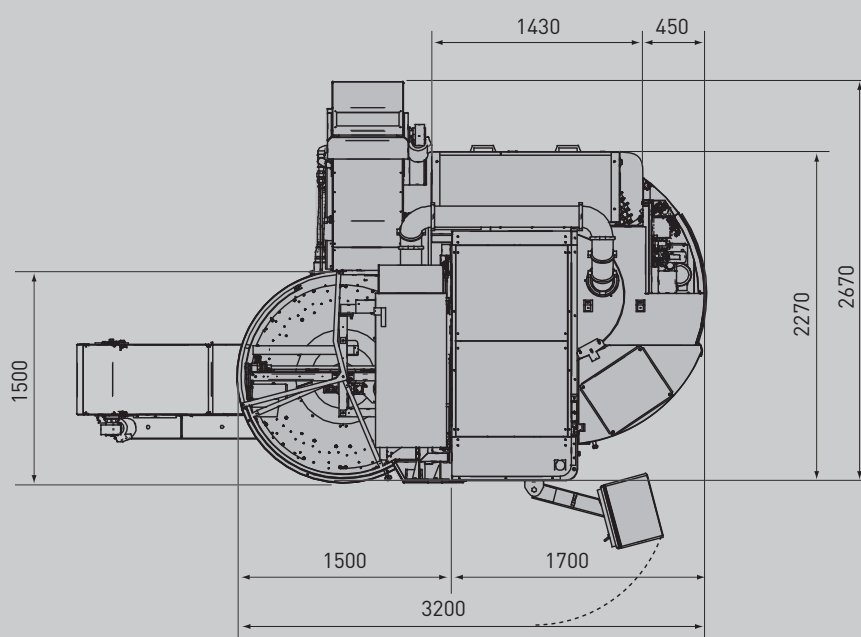
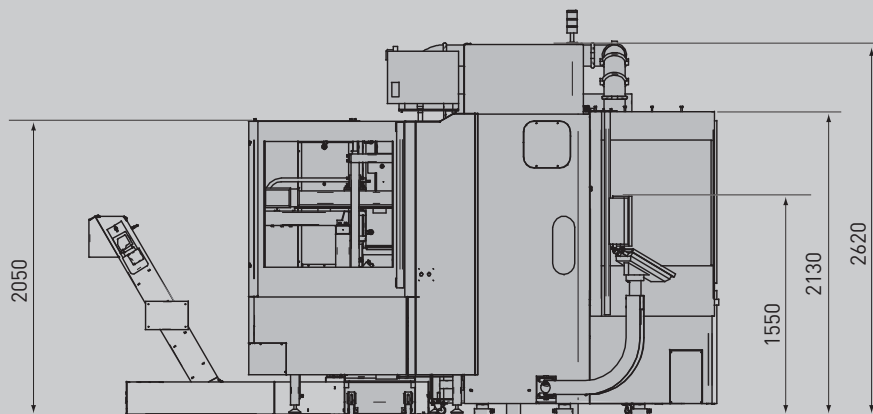

**MIKRON**  
**XSM 400**  
**XSM 400U**